

REV. E	SHEET 1 OF 6	DOCUMENT NO. HDB-D4-XXXXXXX
REVISIONS		
LTR	DESCRIPTION	DATE
A	INITIAL RELEASE	08/08/2007
B	CL (11) SEE CHANGE NOTICE ECNA3601-0000	DM 09/27/2007
C	CL (11) SEE CHANGE NOTICE ECNA5904-0000	NAV 08/22/2008
D	CL (11) SEE CHANGE NOTICE ECNA6108-0000	NAV 09/30/2008
E	CL (11) SEE CHANGE NOTICE ECN: A7939-0000	07/30/2009 D. MORSE

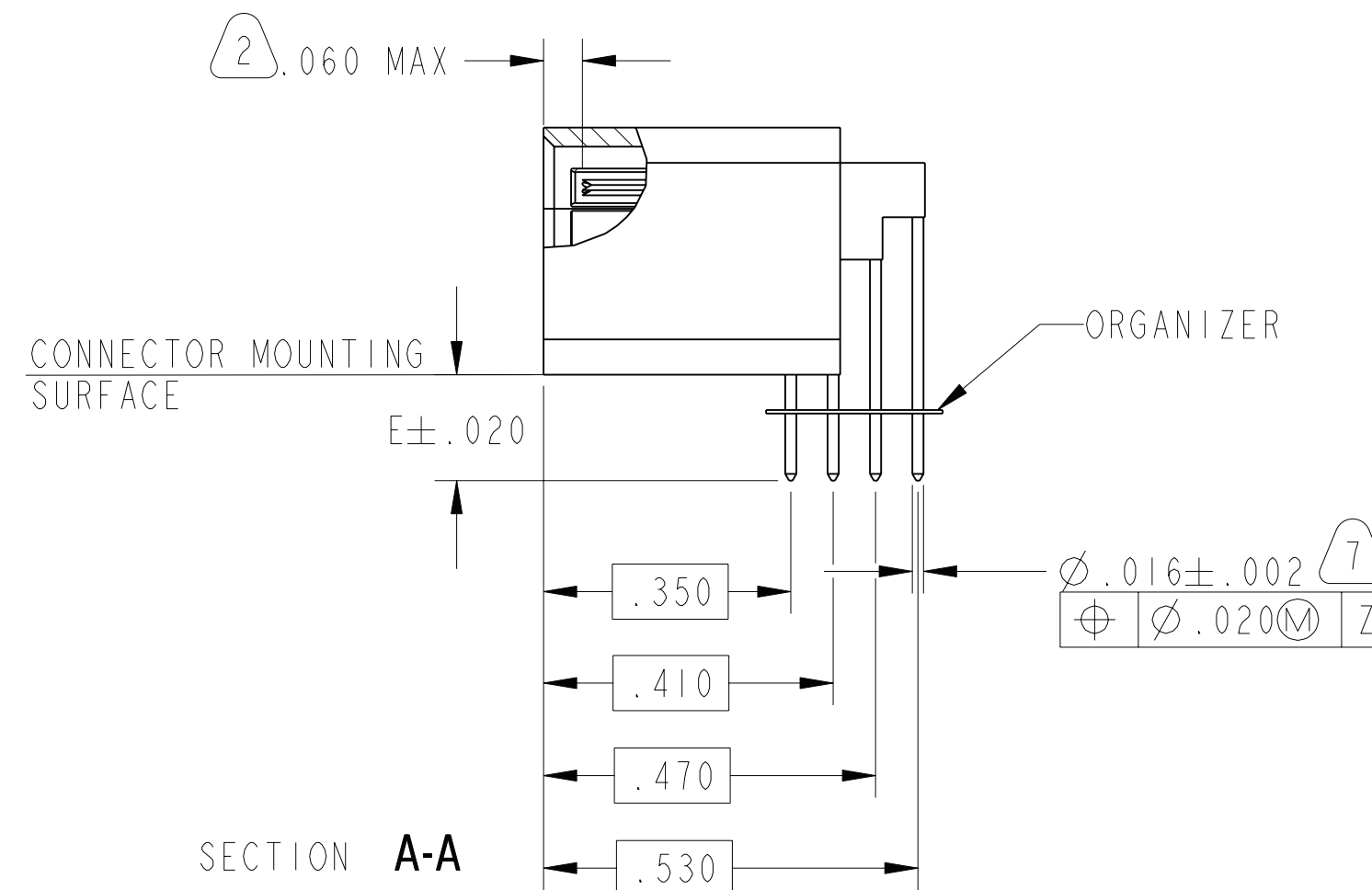
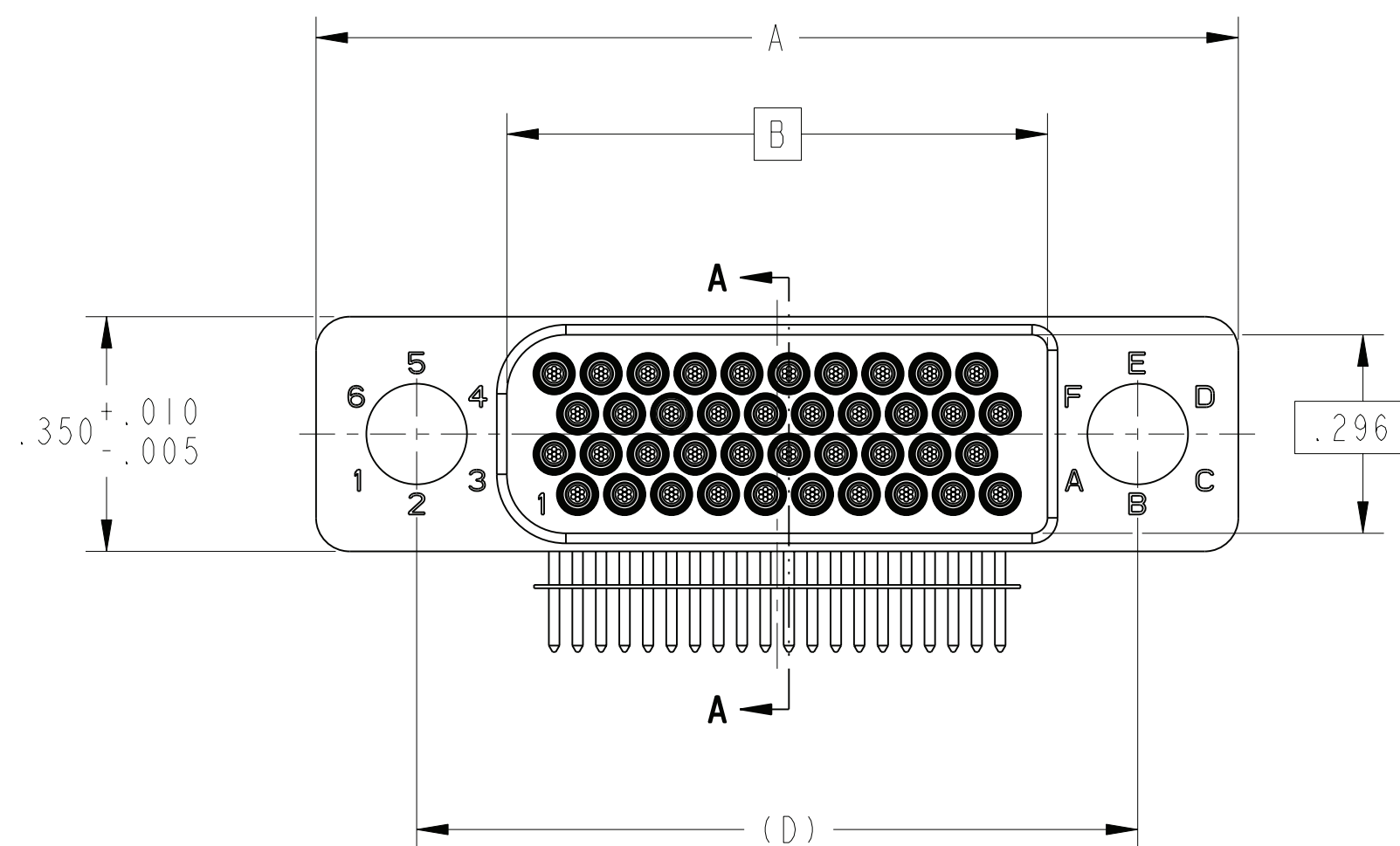
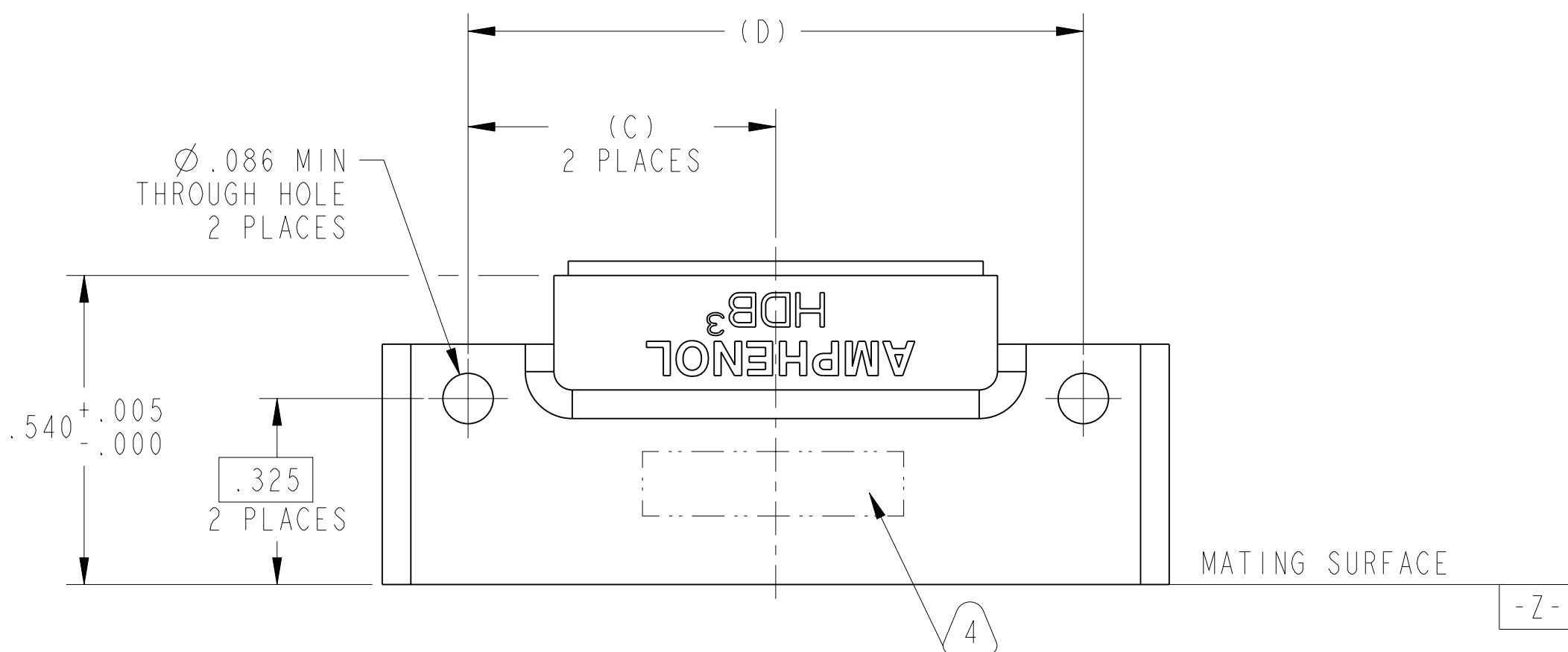

NOTES: SEE SHEET 4

THE USE OF THIS DOCUMENT IS UNLIMITED. HOWEVER, DOCUMENTS REFERENCED HEREON MAY CONTAIN LIMITED RIGHTS DATA.

N/A NEXT ASSEMBLY

PRO/ENGINEER INFORMATION
 Pro/e Model Used:
 HDB-D4-XXXXXXX.ASSEM
 Drawing Name:
 HDB-D4-XXXXXXX

UNLESS OTHERWISE SPECIFIED	SPECIFICATIONS	POS	QTY	PART NUMBER	MADE FROM MHDB-D4-XXXXXXX	DESCRIPTION	NOTE
LINEAR DIMENSIONS ARE IN INCHES TOLERANCES: .XXXX = ±.0005 ANGLES= ±2° .XXX = ±.010 .XX = ±.03 .X = ±.1 DIM. & TOL. PER ASME Y14.5M; DRM PER MIL-DTL-31000; OTHER Amphenol Stds. PER 9-3800 LEGENDS: =FLAG NOTE CALL OUT REFERENCE ONLY	MATERIAL SPEC.	PARTS LIST					
	N/A	AMPHENOL CORPORATION 40-60 DELAWARE AVENUE SIDNEY, N.Y. 13858 4 ROW DAUGHTER BOARD CONNECTOR HDB3 SERIES					
PROCESS SPEC.	9-3895 9-3856-5	APPROVALS		DATE	SIZE C CAGE CODE 77820 DOCUMENT NO. HDB-D4-XXXXXXX REF. N/A SHEET 1 OF 6		
		PREPARED BY DMORSE ENGINEER IN CHARGE BCHUBB DESIGN MANAGER EHICKEY DESIGN ACTIVITY GROUP BLP		17-Jul-07			
		THIRD ANGLE PROJECTION		SCALE: 4.0 SHEET 1 OF 6			

HDB-D4-XXXXXXX

SHEET 1 OF 6

REV. E

C

B

A

FORMAT: C-0-E-1

RELEASE STATE Released
REVISION E
VERSION 3
SHEET 1 OF 6
HDB-D4-XXXXXXX

HDB-D4-XXXXXXXX

SHEET 2 OF 6

REV. E

C

B

A

HDB-D4-XXX X XX X X

EXAMPLE: HDB-D4-040 M 02 2 X

CONTACT TERMINATION FINISH	
2	GOLD PLATED IN ACCORDANCE WITH MIL-G-45204, TYPE II, .000030 MIN THICK GOLD OVER .000050 MIN THICK NICKEL
5	TIN PLATED IN ACCORDANCE WITH ASTM B545, .00010 MIN THICK MATTE TIN OVER .00010 MIN THICK NICKEL. 6
6	TIN-LEAD PLATED IN ACCORDANCE WITH SAE-AMS-P-81728, .00010 MIN THICK TIN-LEAD OVER .00010 MIN THICK COPPER.

TERMINATION		
	TYPE	STICKOUT (DIM E)
00	PCB, RIGHT ANGLE, .016 DIA.	.060
01	PCB, RIGHT ANGLE, .016 DIA.	.090
02	PCB, RIGHT ANGLE, .016 DIA.	.120
03	PCB, RIGHT ANGLE, .016 DIA.	.150
04	PCB, RIGHT ANGLE, .016 DIA.	.180
05	PCB, RIGHT ANGLE, .016 DIA.	.210
06	PCB, RIGHT ANGLE, .016 DIA.	.300

BRUSH WIRE PLATING (CONTACT INTERFACE)	
M	0.000050 Au MIN THK OVER NICKEL
C	0.000020 Au MIN THK OVER NICKEL

CONNECTOR DIMENSIONS					
	NUMBER OF CONTACTS	DIMENSION A	DIMENSION B	DIMENSION C	DIMENSION D
040	40	1.375	.806	.5375	1.075
080	80	2.075	1.506	.8875	1.775
120	120	2.775	2.206	1.2375	2.475
160	160	3.475	2.906	1.5875	3.175
060	60	1.725	1.156	.7125	1.425

NOTES: SEE SHEET 4

THE USE OF THIS DOCUMENT IS UNLIMITED. HOWEVER, DOCUMENTS REFERENCED HEREON MAY CONTAIN LIMITED RIGHTS DATA.

HARDWARE (SUPPLIED UNASSEMBLED)		
		NOTE
X	NO HARDWARE	5
P	POLARIZATION KEY (QTY. 2)	1
L	LOW PROFILE MOUNTING NUT (QTY. 2)	8
J	LOW PROFILE MOUNTING W/ POLARIZATION (2 PCS. QTY. 2 EACH)	10
H	CAPTIVE LOCKING SCREW (QTY. 2)	9
F	CAPTIVE LOCKING HEX CAP SCREW (QTY. 2)	9

RELEASE STATE Released REGION E VERSION 3

REV. E SHEET 2 OF 6

HDB-D4-XXXXXXXX

FORMAT: C-U-E-I

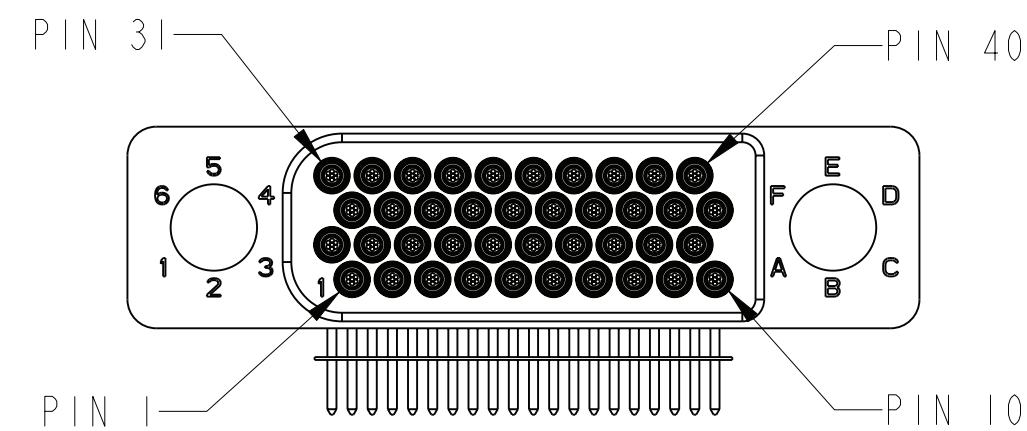

EXAMPLE CONTACT POSITION

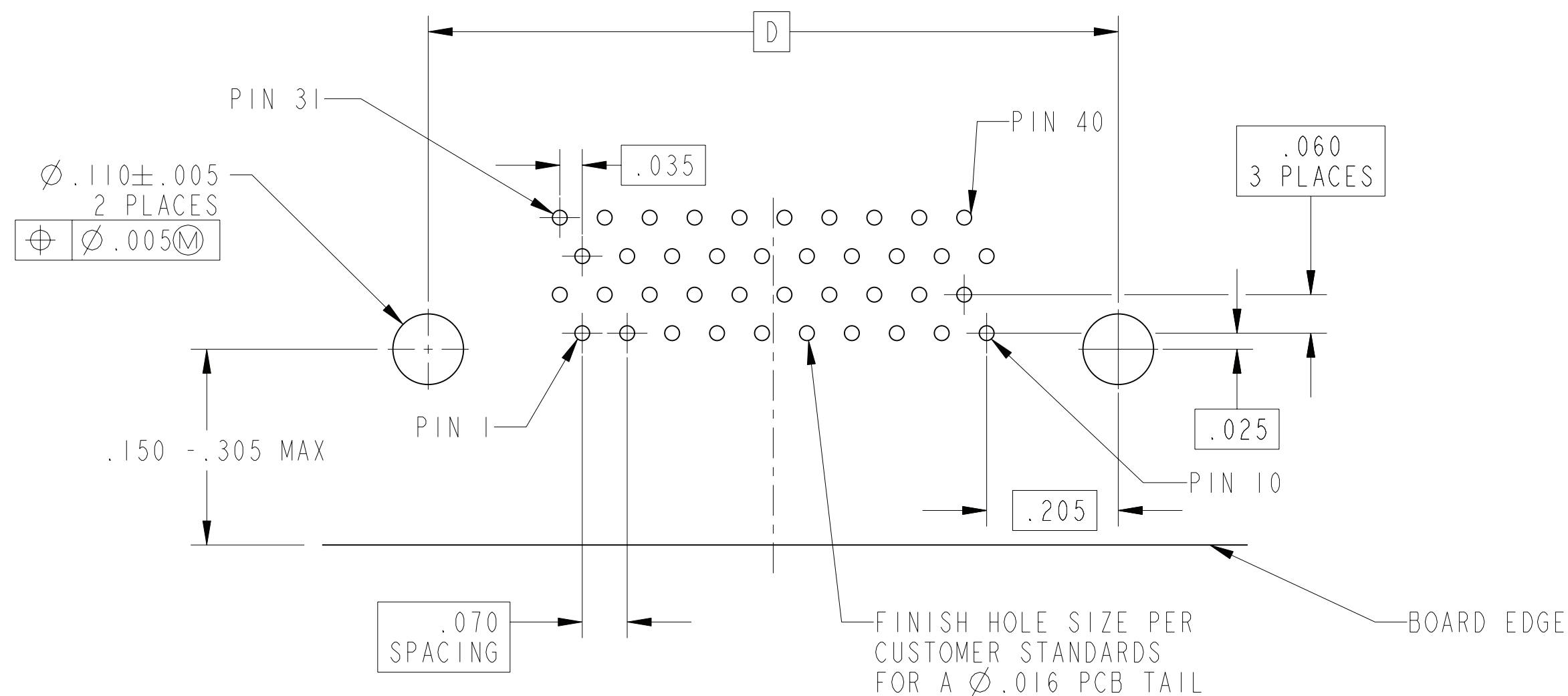

SUGGESTED DAUGHTER BOARD LAYOUT COMPONENT SIDE

SCALE 5.000

NOTES: SEE SHEET 4

THE USE OF THIS DOCUMENT IS UNLIMITED. HOWEVER, DOCUMENTS REFERENCED HEREON MAY CONTAIN LIMITED RIGHTS DATA.

HDB-D4-XXXXXXXXXX

SHEET 4 OF 6

REV. E

10. WHEN USING LOW PROFILE MOUNTING NUT WITH POLARIZATION KEY (SUFFIX J) INSTALL POLARIZATION KEY FIRST THEN ASSEMBLE LOW PROFILE NUT PRIOR TO INSTALLING 2-56 SCREW (NOT SUPPLIED).
9. WHEN CONNECTOR ASSEMBLY REQUIRES HARDWARE SUFFIX "H" AND "F", A THREADED BUSHING WILL BE INSTALLED INTO CONNECTOR BODY BY AMPHENOL MANUFACTURING TO CAPTURE HARDWARE 2 PLACES. SEE EXPLODED ASSEMBLY VIEWS SHEET 5 AND 6.
8. LOW PROFILE MOUNTING NUTS ARE OPTIONAL. WHEN USING, A QUANTITY OF 2 ARE REQUIRED PER CONNECTOR. INSERT LOW PROFILE MOUNTING NUTS FROM REAR OF CONNECTOR PRIOR TO MOUNTING CONNECTOR WITH SCREWS (SCREWS NOT SUPPLIED). WHEN USING LOW PROFILE MOUNTING NUT, MATING CONNECTOR MAY ALSO USE GUIDE PINS.
7. CONTACT ASSEMBLIES ARE NON- REPLACEABLE.
6. RoHS COMPLIANT FOR TERMINATION FINISH TIN PLATE OVER NICKEL.
5. USE A 2-56 SCREW, NUT AND WASHER FOR MOUNTING CONNECTOR ASSEMBLY WITH OR WITHOUT POLARIZATION KEYS. (NOT SUPPLIED)
4. INK STAMP 77820, PART NUMBER AND DATE CODE ON INDICATED SURFACE PER 9-3856-5. DATE CODE PER 9-3895, CHARACTERS TO BE .062 ±.020 HIGH.
3. FOR MATING MOTHER BOARD CONNECTOR ASSEMBLY SEE DRAWING HDB-M4-XXXXXXXX.
2. INDICATED DIMENSION IS TO POINT OF MINIMUM ELECTRICAL ENGAGEMENT.
1. POLARIZATION KEYS ARE OPTIONAL. WHEN USING, A QUANTITY OF 2 ARE REQUIRED PER CONNECTOR. INSERT KEYS FROM REAR OF CONNECTOR PRIOR TO MOUNTING CONNECTOR WITH SCREWS (SEE NOTE 5). WHEN USING KEY, MATING CONNECTOR MUST ALSO USE KEYS.

NOTES:

THE USE OF THIS DOCUMENT IS UNLIMITED. HOWEVER, DOCUMENTS REFERENCED HEREON MAY CONTAIN LIMITED RIGHTS DATA.

REPLACEMENT HARDWARE			
HW ID	TYPE	PART NUMBER	NOTE
P	POLARIZATION KEY QTY 2	HDB-508804-000	1
L	LOW PROFILE MOUNTING NUT QTY 2	HDB-508804-001	8
J	LOW PROFILE POLARIZATION KEY QTY 2 LOW PRO. MOUNT NUT FOR POLARIZATION QTY 2 (BOTH COMPONENTS REQUIRED)	HDB-508804-002 HDB-508804-003	10
H	CAPTIVE LOCKING SCREW QTY. 2	HDB-508806-030	
F	CAPTIVE LOCKING HEX CAP SCREW (QTY.2)	HDB-508804-005	

SIZE C	CAGE CODE 77820	DOCUMENT NO. HDB-D4-XXXXXXXXXX	REV. E
SCALE: 3.0	REF: N/A	SHEET 4 OF 6	

RELEASE STATE Released	REVISION E	VERSION 3
---------------------------	---------------	--------------

SHEET 4 OF 6

HDB-D4-XXXXXXXXXX

REV. E

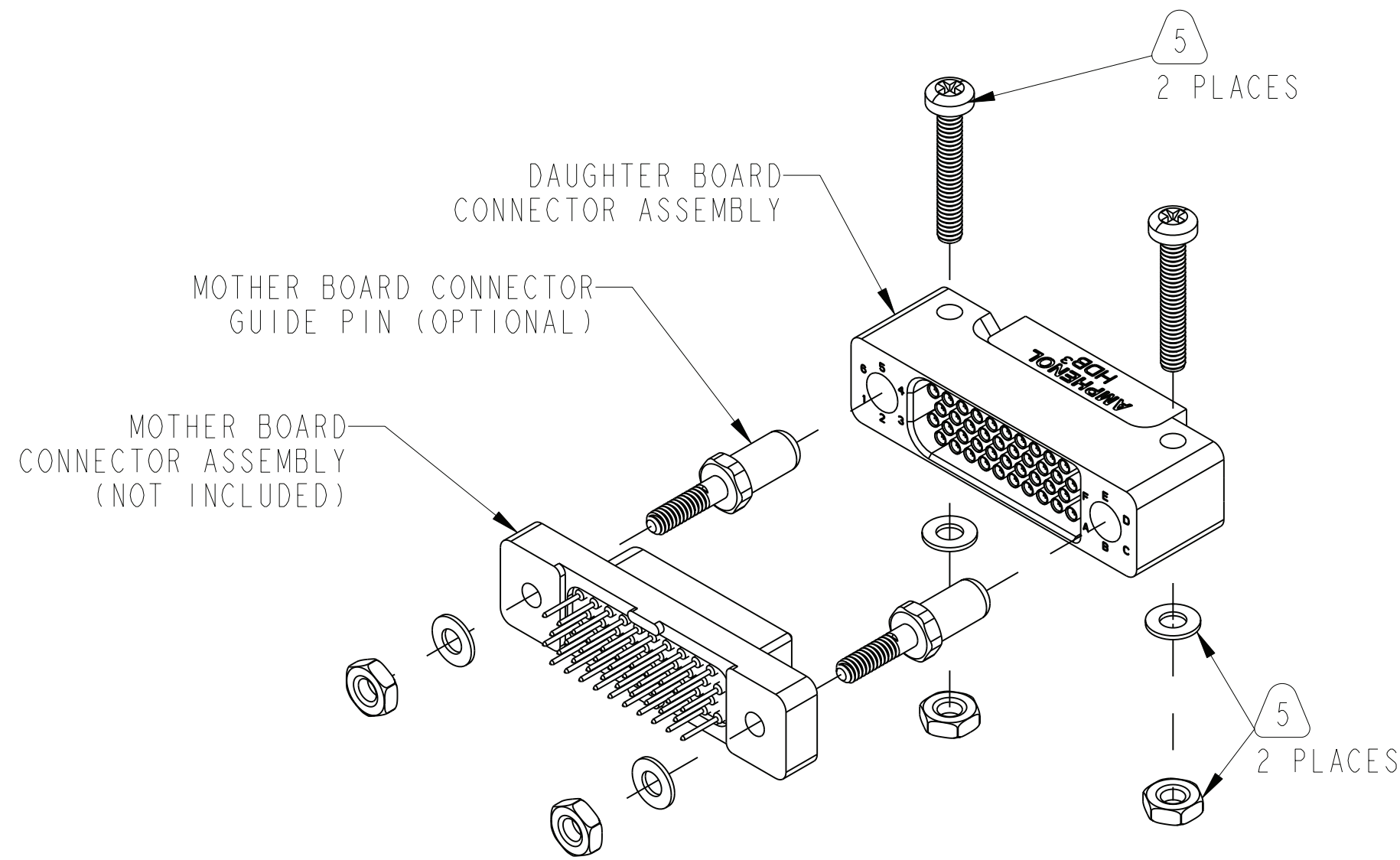

EXPLODED ISOMETRIC VIEW
SHOWN WITH OPTIONAL
GUIDE PIN

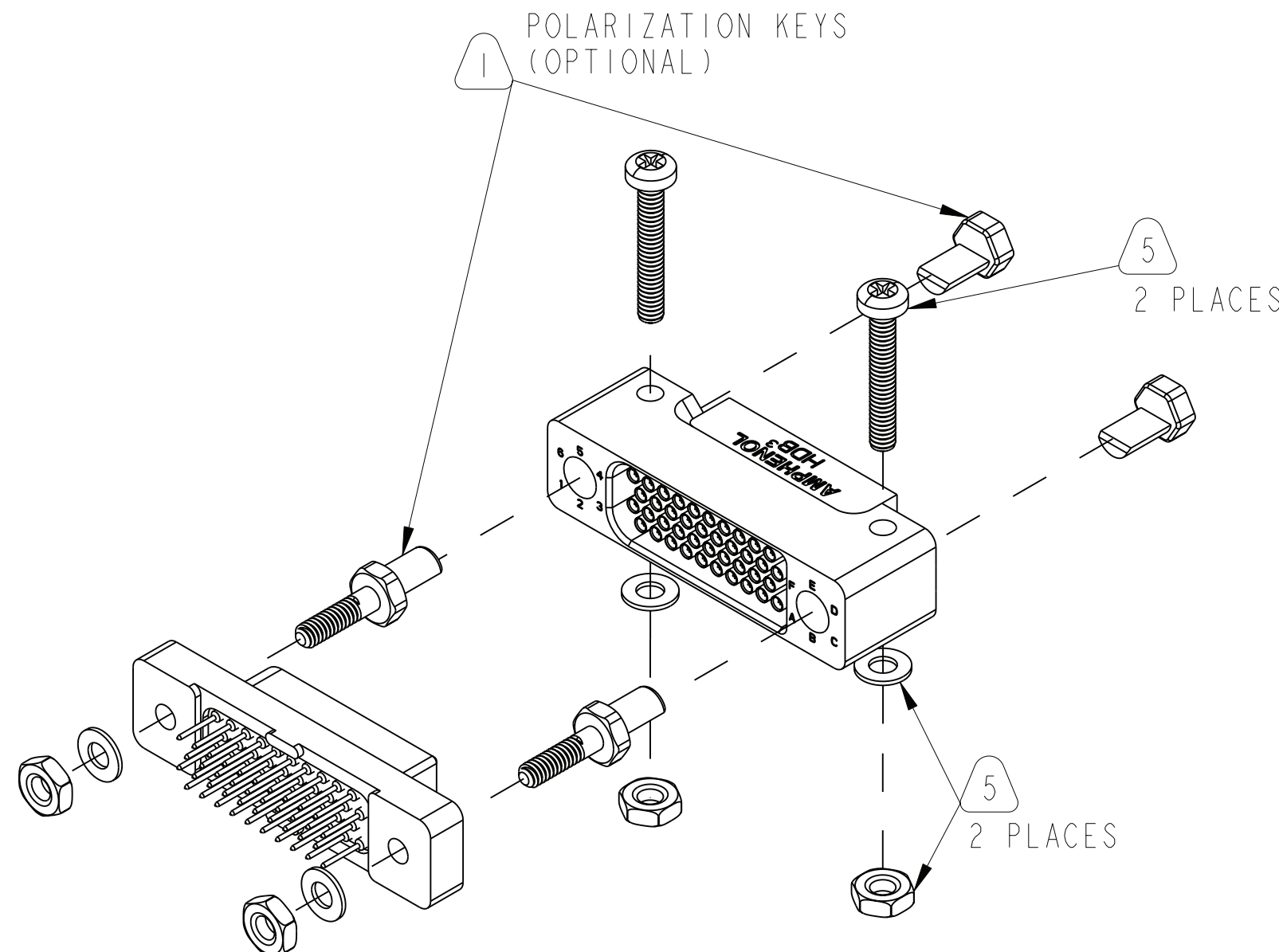

EXPLODED ISOMETRIC VIEW
SHOWN WITH OPTIONAL KEYING

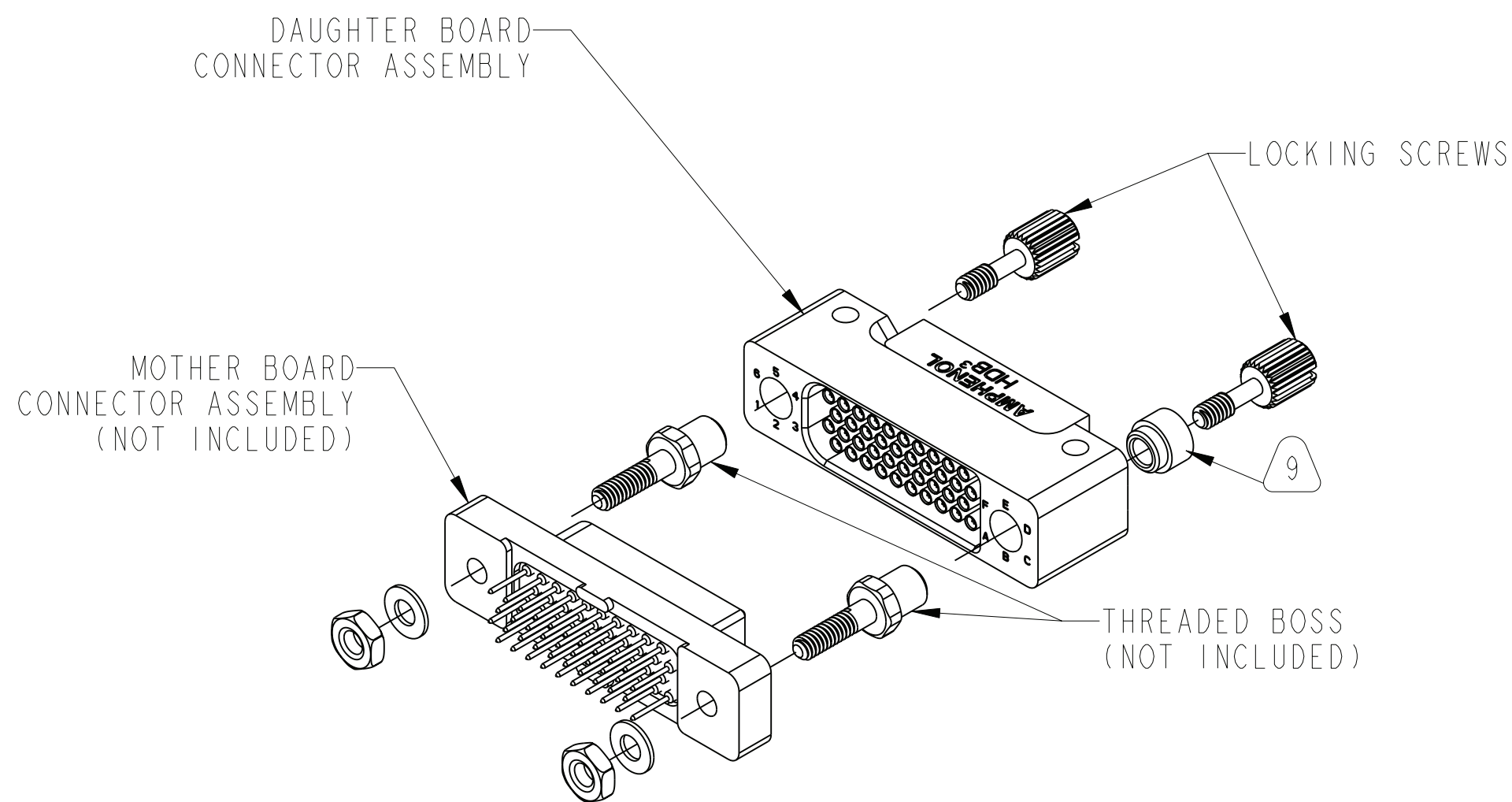

EXPLODED ISOMETRIC VIEW
SHOWN WITH OPTIONAL
CAPTIVE LOCKING SCREW

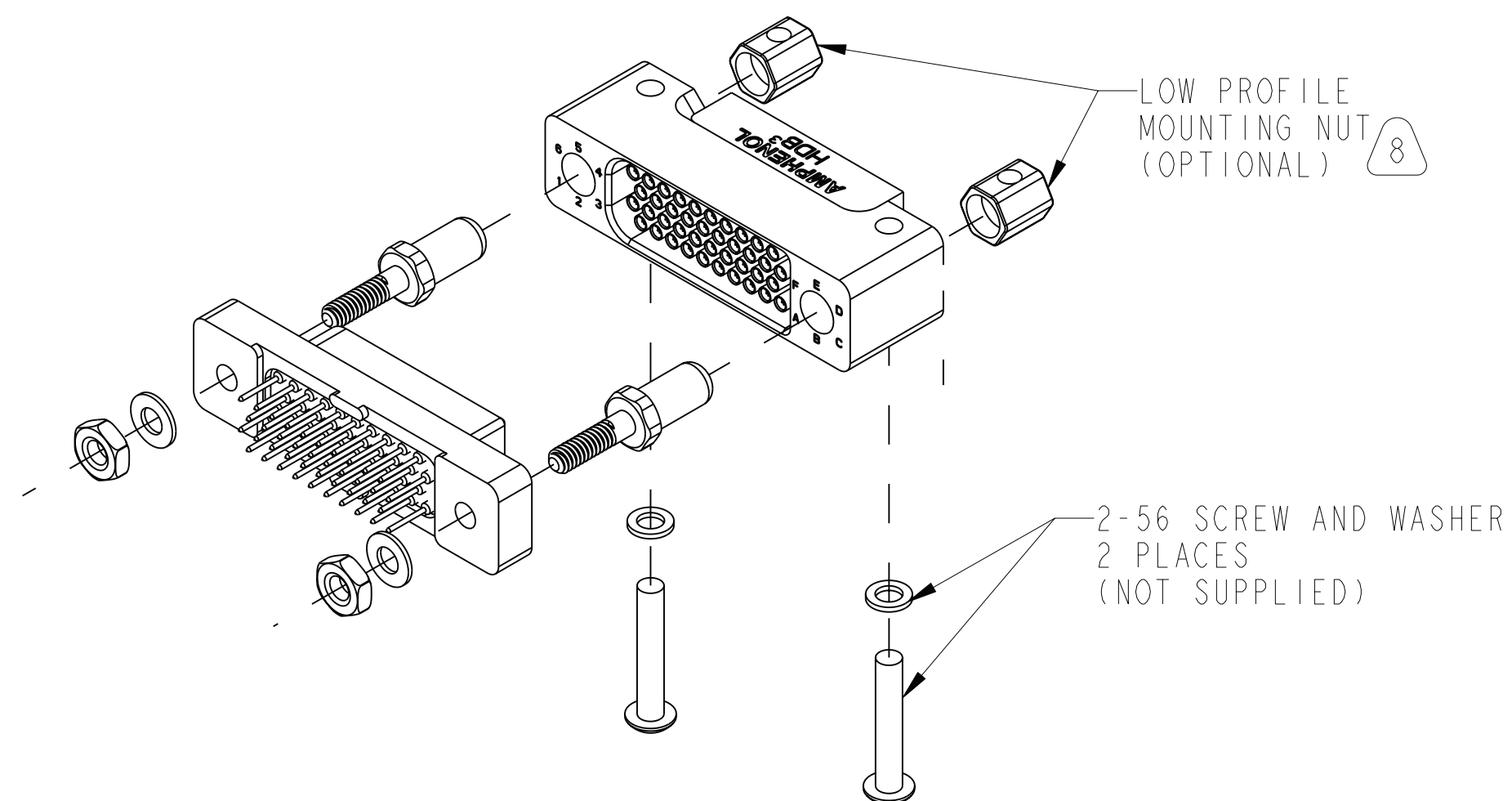

EXPLODED ISOMETRIC VIEW
SHOWN WITH OPTIONAL
LOW PROFILE MOUNTING NUT

NOTES: SEE SHEET 4

THE USE OF THIS DOCUMENT IS UNLIMITED.
HOWEVER, DOCUMENTS REFERENCED HEREON
MAY CONTAIN LIMITED RIGHTS DATA.

SIZE C	CAGE CODE 77820	DOCUMENT NO. HDB-D4-XXXXXXX	REV. E
SCALE: 1.0		REF: N/A	SHEET 5 OF 6

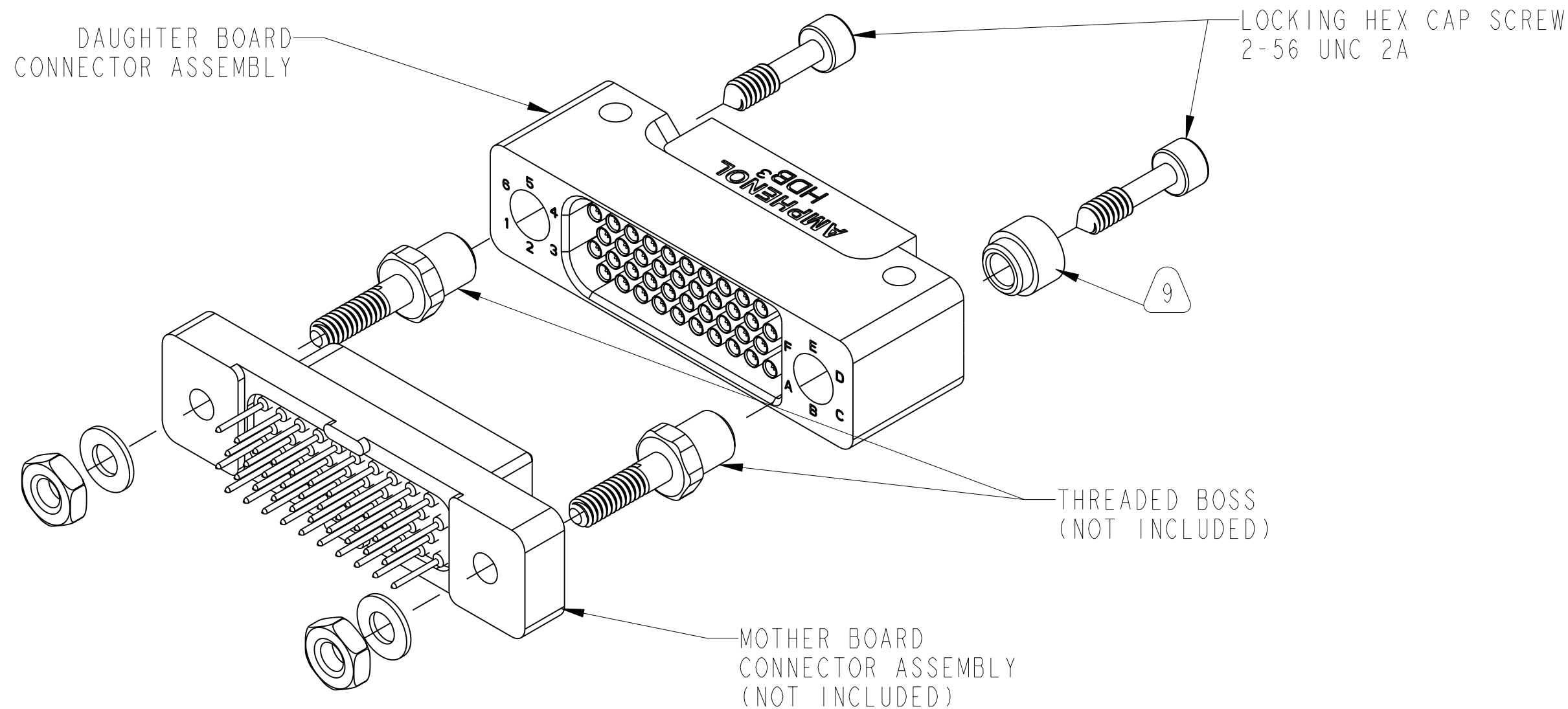

EXPLODED ISOMETRIC VIEW
SHOWN WITH OPTIONAL
CAPTIVE LOCKING HEX CAP SCREW

NOTES: SEE SHEET 4

THE USE OF THIS DOCUMENT IS UNLIMITED.
HOWEVER, DOCUMENTS REFERENCED HEREON
MAY CONTAIN LIMITED RIGHTS DATA.