

SNAP LATCH ASSEMBLY P/N DESCRIPTION :

R - M A 1 - X - X P X X - X X X - X	
1 BONDED	
2 MEDICAL	
3 STYLE	A1=PA (Straight Plug with cable collet.) ----SOLDER TERMINATION
4 OUTER SHELL MATERIAL	G=GREY PSU B=BLACK PSU M=WHITE PSU F=BLACK PEI P=GREY PEI
5 BACK NUT MATERIAL	0=BLACK 1=WHITE 2=RED 4=YELLOW 5=GREEN 6=BLUE 8=GREY
6 INSULATOR	P=PEEK
7 CONTACT DIAMETER	1=1.3mm (ONLY FOR 2;3 PIN) 2=0.9mm (ONLY FOR 4;5 PIN) 3=0.7mm (ONLY FOR 6;7;8 PIN) 4=0.5mm (ONLY FOR 9;10;12;14 PIN)
8 CONTACT PLATING	1=GOLD PLATED 1u" 2=GOLD PLATED 20u"
9 CABLE COLLET	1=Ø3.9mm (CABLEØ=2.7~3.9mm) 2=Ø5.2mm (CABLEØ=4.0~5.2mm) 3=Ø6.5mm (CABLEØ=5.3~6.5mm)
10 CODING	0= 0° A= 40° C= 60° E= 80° H= 170° S= 190° J= 205°
11 NUMBER OF CONTACTS	02= 2 PIN 03= 3 PIN 04= 4 PIN 05= 5 PIN 06= 6 PIN 07= 7 PIN 08= 8 PIN 09= 9 PIN 10= 10 PIN 12= 12 PIN 14= 14 PIN
12 LOGO	0="nexttron" LOGO AND "GRASP HERE" LOGO G=NO LOGO,WITH "GRASP HERE" LOGO

POSITIONS	VIEW FROM TERMINATION SIDE
	PIN PART
2 PIN	
3 PIN	
4 PIN	
5 PIN	
6 PIN	
7 PIN	
8 PIN	
9 PIN	
10 PIN	
12 PIN	
14 PIN	

NOTES :

- MATERIAL  
OUTER SHELL : PSU/PEI  
INSULATOR : PEEK  
CONTACT : COOPER ALLOY  
CABLE COLLET : PSU/PEI  
BACK NUT : PSU/PEI
- NUMBER OF CONTACT : 2 TO 14 POSITION
- ALL DIMENSIONS ARE IN MILLIMETERS.
- RoHS DIRECTIVE COMPLIANCE

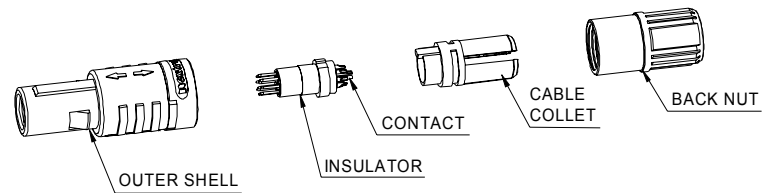
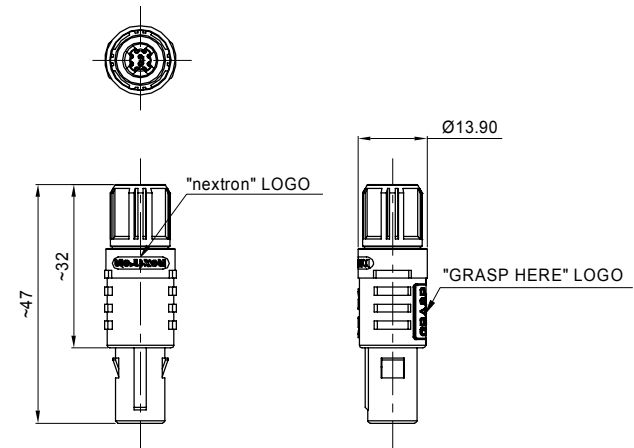

UNITS: ■ mm □ inch	SIZE A3	NAME: SNAP LATCH (Straight Plug)	<b>nexttron</b> <sup>®</sup> NEXTRONICS ENGINEERING CORP.	
GENERAL TOLERANCE: (UNLESS SPECIFIED)		PART NO: RMA1XXPXXXXXXX	TITLE: CUSTOMER DWG.	
	mm inch	APPD: Alex梁良駒 2019/11/11	DWG NO: 010-0000-458	
4 PLACE	± ** ± **	CHKD: Alex梁良駒 2019/11/11	<b>C</b>	
3 PLACE	± ** ± **	DRAW: Ellen孫郁婷 2019/10/30		
2 PLACE	± 0.20 ± **	DESIGN: Kim徐育金 2019/10/30	SCALE	SHEET
1 PLACE	± 0.50 ± **		1/1	1/3
ANGLES	X° ± 3°		REV.	B5

B5	UPDATE DWG.	10/26'19
REV.	DESCRIPTION	DATE

CONFIDENTIAL: THIS DOCUMENT CONTAINED THE INFORMATION IS PROPRIETARY AND CONFIDENTIAL TO Nexttronics Engineering Corp. NO PERSON IS ALLOWED TO USE COPY, PUBLISH OR OTHERWISE DISCLOSE THE INFORMATION TO OTHERS, UNLESS BY THE PRIOR WRITTEN EXPRESS AUTHORIZATION OF Nexttronics Engineering Corp. (C)COPYRIGHT- Nexttronics Engineering Corp.

1 2 3 4 5 6 7 8

SNAP LATCH ASSEMBLY P/N DESCRIPTION :

R - M A 3 - X - X P X X - X X X - X

- 1 BONDED \_\_\_\_\_
- 2 MEDICAL \_\_\_\_\_
- 3 STYLE A3=PA (Straight Plug with cable collet and nut for fitting a bend relief.)  
----SOLDER TERMINATION \_\_\_\_\_
- 4 OUTER SHELL MATERIAL  
G=GREY PSU \_\_\_\_\_  
B=BLACK PSU \_\_\_\_\_  
M=WHITE PSU \_\_\_\_\_  
F=BLACK PEI \_\_\_\_\_  
P=GREY PEI \_\_\_\_\_
- 5 BACK NUT MATERIAL  
0= BLACK \_\_\_\_\_  
(SAME AS THE OUTER SHELL)  
1= WHITE \_\_\_\_\_  
(SAME AS THE OUTER SHELL)  
8= GERY \_\_\_\_\_  
(SAME AS THE OUTER SHELL)
- 6 INSULATOR P=PEEK \_\_\_\_\_
- 7 CONTACT DIAMETER  
1=1.3mm (ONLY FOR 2;3 PIN) \_\_\_\_\_  
2=0.9mm (ONLY FOR 4;5 PIN) \_\_\_\_\_  
3=0.7mm (ONLY FOR 6;7;8 PIN) \_\_\_\_\_  
4=0.5mm (ONLY FOR 9;10;12;14 PIN) \_\_\_\_\_
- 8 CONTACT PLATING  
1=GOLD PLATED 1u" \_\_\_\_\_  
2=GOLD PLATED 20u" \_\_\_\_\_
- 9 CABLE COLLET  
1=Ø3.9mm (CABLEØ=2.7~3.9mm) \_\_\_\_\_  
2=Ø5.2mm (CABLEØ=4.0~5.2mm) \_\_\_\_\_  
3=Ø6.5mm (CABLEØ=5.3~6.5mm) \_\_\_\_\_
- 10 CODING  
0= 0° \_\_\_\_\_  
A= 40° \_\_\_\_\_  
C= 60° \_\_\_\_\_  
E= 80° \_\_\_\_\_  
H= 170° \_\_\_\_\_  
S= 190° \_\_\_\_\_  
J= 205° \_\_\_\_\_
- 11 NUMBER OF CONTACTS  
02= 2 PIN \_\_\_\_\_  
03= 3 PIN \_\_\_\_\_  
04= 4 PIN \_\_\_\_\_  
05= 5 PIN \_\_\_\_\_  
06= 6 PIN \_\_\_\_\_  
07= 7 PIN \_\_\_\_\_  
08= 8 PIN \_\_\_\_\_  
09= 9 PIN \_\_\_\_\_  
10= 10 PIN \_\_\_\_\_  
12= 12 PIN \_\_\_\_\_  
14= 14 PIN \_\_\_\_\_
- 12 LOGO  
0="nextron" LOGO AND "GRASP HERE" LOGO \_\_\_\_\_  
G=NO LOGO, WITH "GRASP HERE" LOGO \_\_\_\_\_

POSITIONS	VIEW FROM TERMINATION SIDE
2 PIN	
3 PIN	
4 PIN	
5 PIN	
6 PIN	
7 PIN	
8 PIN	
9 PIN	
10 PIN	
12 PIN	
14 PIN	

NOTES :

1. MATERIAL  
OUTER SHELL : PSU/PEI  
INSULATOR : PEEK  
CONTACT : COOPER ALLOY  
CABLE COLLET : PSU/PEI  
BACK NUT : PSU/PEI
2. NUMBER OF CONTACT : 2 TO 14 POSITION
3. ALL DIMENSIONS ARE IN MILLIMETERS.
4. RoHS DIRECTIVE COMPLIANCE

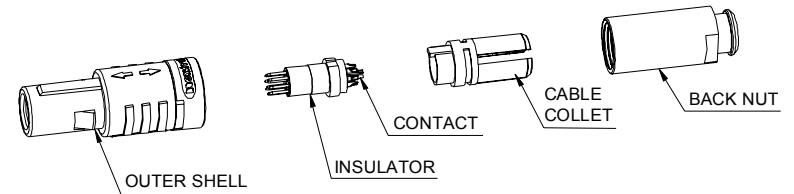
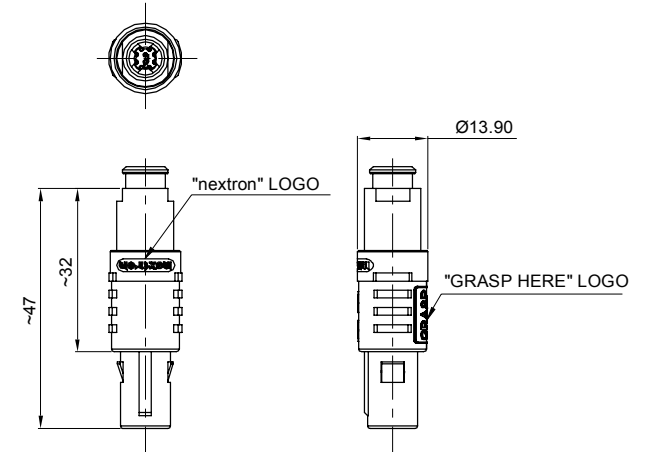

UNITS: ■ mm □ inch	SIZE A3	NAME: SNAP LATCH (Straight Plug)	 NEXTRONICS ENGINEERING CORP.		
GENERAL TOLERANCE: (UNLESS SPECIFIED)		PART NO: RMA3XPXXXXXX	TITLE: CUSTOMER DWG.		
4 PLACE	± **	mm	APPD: Alex梁良駒	2019/11/11	DWG NO: 010-0000-458
3 PLACE	± **	inch	CHKD: Alex梁良駒	2019/11/11	
2 PLACE	± 0.20	mm	DRAW: Ellen孫郁婷	2019/10/30	SCALE SHEET REV. 1/1 2/3 B5
1 PLACE	± 0.50	inch	DESIGN: Kim徐育金	2019/10/30	
ANGLES	X° ± 3°				

B5	UPDATE DWG.	10/26'19
REV.	DESCRIPTION	DATE

CONFIDENTIAL: THIS DOCUMENT CONTAINED THE INFORMATION IS PROPRIETARY AND CONFIDENTIAL TO Nexttronics Engineering Corp. NO PERSON IS ALLOWED TO USE COPY, PUBLISH OR OTHERWISE DISCLOSE THE INFORMATION TO OTHERS, UNLESS BY THE PRIOR WRITTEN EXPRESS AUTHORIZATION OF Nexttronics Engineering Corp. (C)COPYRIGHT- Nexttronics Engineering Corp.

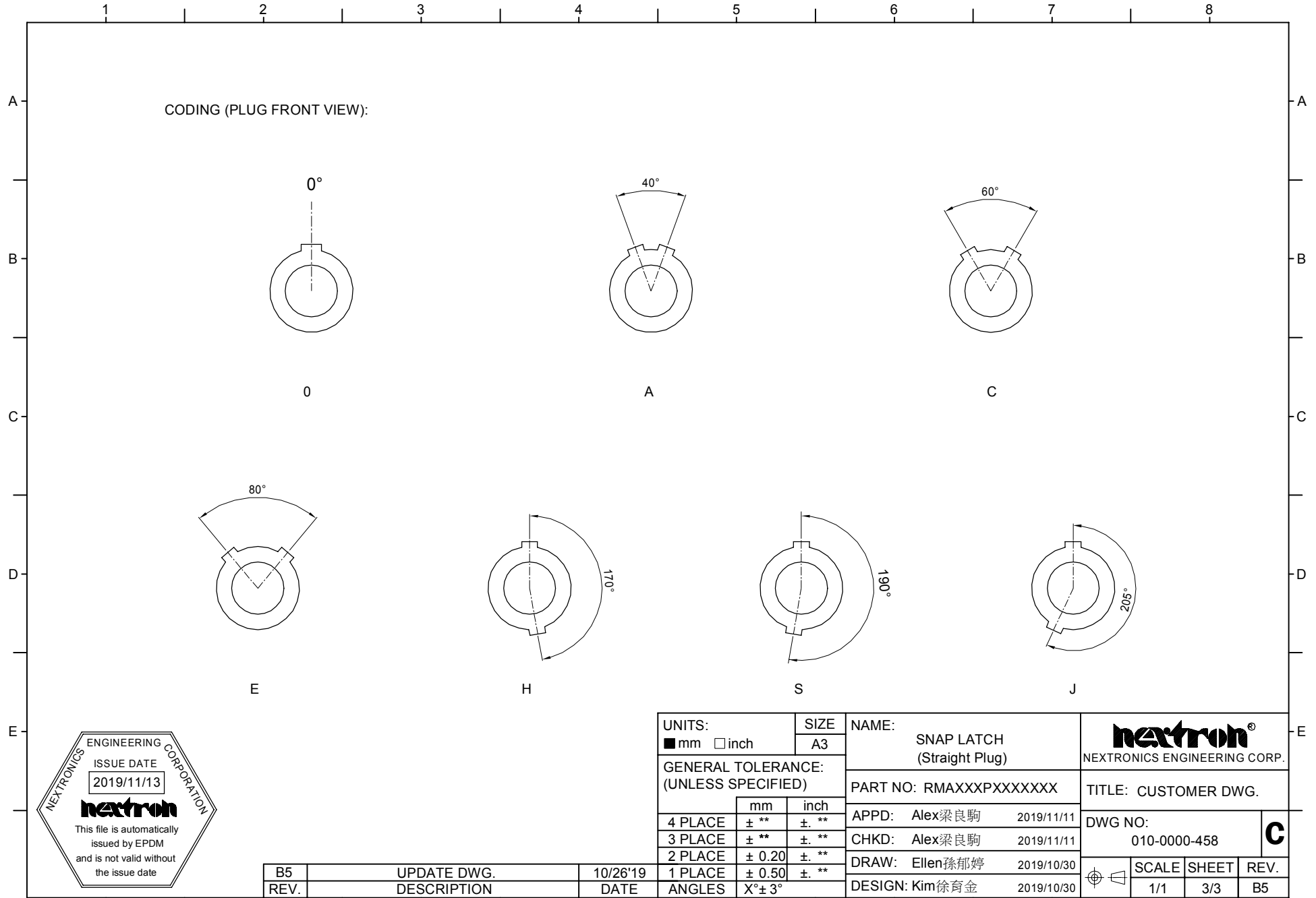

B5	UPDATE DWG.	10/26'19
REV.	DESCRIPTION	DATE

UNITS: ■ mm □ inch	SIZE A3	NAME: SNAP LATCH (Straight Plug)	NEXTRONICS ENGINEERING CORP.							
GENERAL TOLERANCE: (UNLESS SPECIFIED)		PART NO: RMAXXPXXXXXX	TITLE: CUSTOMER DWG.							
	mm	inch	APPD: Alex梁良駒	2019/11/11						
4 PLACE	± **	± **	CHKD: Alex梁良駒	2019/11/11						
3 PLACE	± **	± **	DRAW: Ellen孫郁婷	2019/10/30						
2 PLACE	± 0.20	± **	DESIGN: Kim徐育金	2019/10/30						
1 PLACE	± 0.50	± **								
ANGLES	X° ± 3°			<table border="1"> <tr> <td>SCALE</td> <td>SHEET</td> <td>REV.</td> </tr> <tr> <td>1/1</td> <td>3/3</td> <td>B5</td> </tr> </table>	SCALE	SHEET	REV.	1/1	3/3	B5
SCALE	SHEET	REV.								
1/1	3/3	B5								

CONFIDENTIAL: THIS DOCUMENT CONTAINED THE INFORMATION IS PROPRIETARY AND CONFIDENTIAL TO Nexttronics Engineering Corp. NO PERSON IS ALLOWED TO USE COPY, PUBLISH OR OTHERWISE DISCLOSE THE INFORMATION TO OTHERS, UNLESS BY THE PRIOR WRITTEN EXPRESS AUTHORIZATION OF Nexttronics Engineering Corp. (C)COPYRIGHT- Nexttronics Engineering Corp.